

## EEGT Series

# 100KW Wind Turbine Controller On-grid



## Product Features:

- The product is manufactured according the JB/T6939.1-2004 industrial standard and GB/T 19115.1-2003 national standard also with users' technical requirements.
- Big LCD display. The images tell working state visually. Various data show: real-time wind turbine voltage, current, solar panel voltage, current, DC output voltage, current, total power generation(The main board is with button battery, in case of power failure, history data can be saved for 30 days)
- Two sets of control systems: PWM constant voltage system and three-phase dump load system.
- PWM constant voltage control is 120% of the rated power of the wind turbine. In case exceeding of PWM's capacity, the three-phase dump load will automatically start immediately. After 10-20 minutes, the three-phase dump load will stop and the wind turbine will re-start to resume power supply to ensure the safe running of the overall wind turbine generation system.
- When the strong or super-strong wind conditions, the controller can conduct constant voltage output to ensure the inverter safety running.
- When the condition of disconnected grid-connected inverter, the controller can conduct constant voltage output and wait for inverter resumption.
- When the grid is cut off, the three-phase dump load of the controller will automatically start to work and the inverter will stop output to grid. When the grid resuming, the controller stops three-phase dump load and the inverter will resume power supply.
- The inside of the controller is equipped with surge protector. Contain the over voltage into the wind turbine under the bearable voltage of the equipment or system. On another way, to conduct the strong lightening current into the earth directly to avoid any damage of equipment.
- The controller is equipped with emergency stop switch; in case of emergency, press down the emergency stop button in the front panel to cut off all power supply of the controller and the wind turbine will immediately brake ( three-phase dump load ) .
- The controller is equipped with manual three-phase dump load switch. To using this switch, the wind turbine will brake (three-phase dump load).

## Optional Functions:

- Adopt Modbus Communication protocol. Convenient to carry out the secondary development.
- Adjusting the technical specification via RS485 is available. Convenient to adjust the different wind turbines for professional customers.
- Support WIFI and GPRS. Customers can monitor the real-time working state of the on grid wind power system via PC and mobile and query history working state. Both Android and OS are compatible in Mobile.
- Can increase the solar panel control system according to customer requirements.
- For the different wind turbine, the controller can be equipped with mechanical yawing, rotate tail control, furred empennage, mechanical brake, hydraulic brake, electromagnetism brake and other brake functions.

## Connection Diagram:

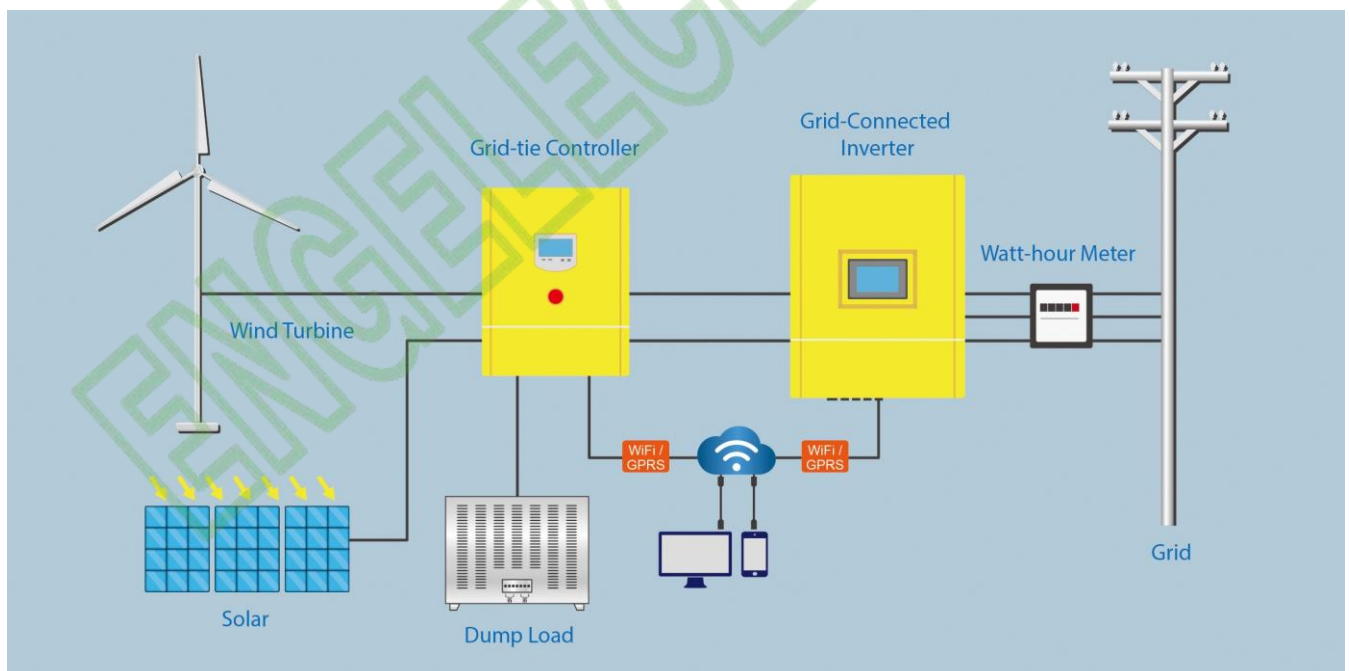

## Technical Parameters

Type	EEGT-100KW
Wind turbine rated power	100KW
Wind turbine Max. power	200KW
Wind turbine rated voltage	AC400V
Function	Rectifier,control,DC output
Automatic protection function	Over voltage protection, network electric cut off protection, regulated supply output, arrester
Manual function	Manual brake, reset, emergency switch
Display mode	LCD
Display content	Wind turbine voltage, current, power; Solar voltage, current, power; DC output voltage, DC output current, DC output power, total power.
PWM constant voltage1	≥560Vdc
wind turbine 3-phase dump load voltage1	580±5Vdc
three-phase dump load 1 delay time	12-20 min
wind turbine 3-phase dump load voltage2	600±5Vdc
three-phase dump load 2 delay time	12-20 min
wind turbine 3-phase dump load voltage3	600±5Vdc
three-phase dump load 3 delay time	12-20 min
PWM dump load fuse	63A*2
Fuse of DC output	250A
Connecting wire of the PWM dump load	>15mm <sup>2</sup>
Connecting wire of the dump load	>16mm <sup>2</sup>

Work environment temperature	-30-60°C
Relative humidity	<90% No condensation
Noise (1m)	<40dB
Degree of protection	IP20 (Indoor)
Cooling method	Forced air cooling
Communication interface	RS485/USB/GPRS/WIFI/Ethernet(optional)
Temperature compensation	-4mv/°C/2V,-35°C~+80°C,Accuracy:±1°C
Size of the controller (mm)	600*500*1200mm
Weight of the controller	96Kg
Size of the dump load (mm)	720*500*1300(2pcs)
Weight of the dump load	107Kg*2

**\*Above parameter only for reference only. Could be custom made to user specifications. Can add solar power control function.**



## APP

APP is intelligent terminal for hybrid wind solar power, PV power station monitoring and management person. It helps users to master power station running status at anytime and anywhere, realize remote data monitoring of hybrid wind solar power and PV power station, ensure convenient management and monitoring timeliness. System displays hybrid wind solar power station and PV power station running data by visual table, includes power station power generation, benefit, CO2 emission reduction benefit, equipment running status, equipment real-time data, history data query, power generation comparison, equipment performance comparison. As fashion and intelligent application, it can let user demonstrate his hybrid wind solar power station and PV power station at any occasion, user has intuitive feeling, enhance user confidence.

- Various data output interface, support Android, iphone, ipad, windows, macOS
- Delicate and precise data, easy to operate, download and install, Wechat binded, real-time monitoring, data synchronization
- 24-hour monitoring
- Low maintenance cost
- Power station information sharing function



## Optional Parts



1.RS485 to WIFI



2.RS485 to GPRS



3.RS485 to Ethernet



4.RS485 to USB

**Project Sample:**





